

# MACTECH

## DWS-48i-AF-SS DIAMOND WIRE SAW 48" INLINE

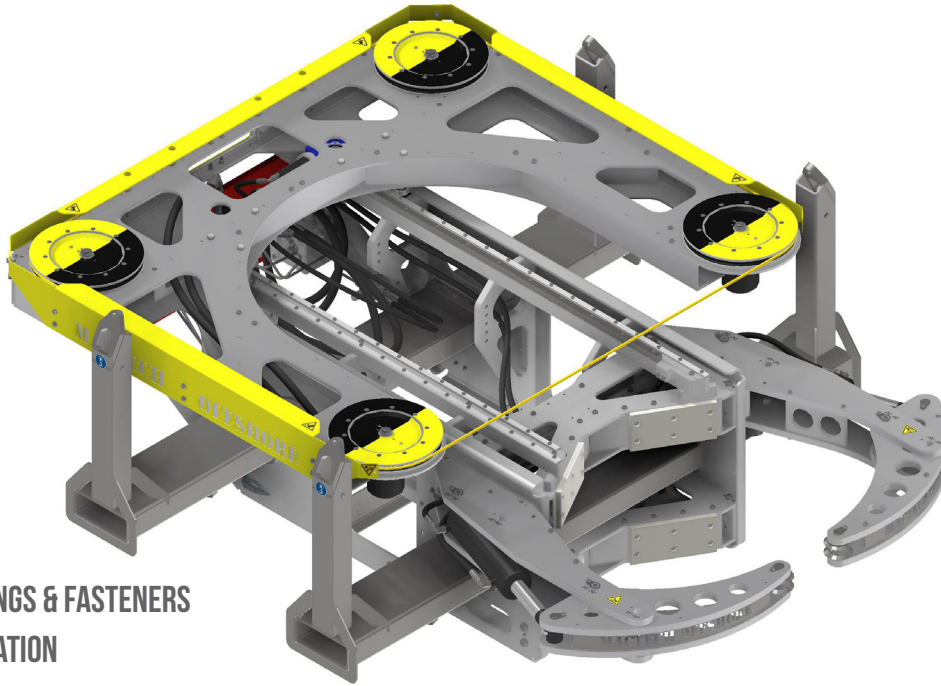

**PART# 607-0209**

**INLINE SAW**

**STAINLESS STEEL FITTINGS & FASTENERS**

**AUTOMATIC FEED OPERATION**

SPECIFICATIONS		HYDRAULIC REQUIREMENTS	
Cutting Capacity	Ø 20" - Ø 48"	Drive	15 gpm @ 3000 psi
	Ø 508 - Ø 1219mm		57 lpm @ 207 bar
Operating Dimensions	134" x 94" x 43"	Feed	.5 gpm @ 650 psi
	3403 x 2387 x 1092mm		2 lpm @ 49 bar
Operating Weight	(Dry) 2150 lbs / (Wet) 1600lbs	Clamp	.5 gpm @ 1500 psi
	(Dry) 975kg / (Wet) 726kg		2 lpm @ 103 bar
ACCESSORIES AVAILABLE		PART NUMBER	
Water Hose System		607-0237	
Diamond Wire (Steel)		443-4810P-0290	
Diamond Wire (Concrete)		443-4010R-0290	
Diamond Wire (Premium Concrete)		443-4410R-0290	
Hydraulic Control Cart		607-0105	
Support Package (Box, SP, TK)		607-0209-PKG	
Spares Kit		607-0209-SP	
Tool Kit		607-0209-TK	

All dimensions and hydraulic requirements are for reference and may be subject to change without notice. Machine performance is subject to application and operator capability; please discuss your requirements directly with a Mactech sales representative. All information given and all sales made by Mactech Inc. are subject to their terms and conditions.

**MACTECH INC.**  
4079 PEPIN AVE UNIT 4  
RED WING MN 55066  
800-328-1488  
INFO@MACTECHONSITE.COM

**MACTECH OFFSHORE**  
302 IDA ROAD  
BROUSSARD LA 70518  
337-839-2793  
INFO@MACTECHOFFSHORE.COM

**MACTECH KENTUCKY**  
3880 INDUSTRIAL DRIVE  
PADUCAH KY 42001  
270-442-1559  
INFO@MACTECHONSITE.COM

**MACTECH WISCONSIN**  
2515 CLEVELAND AVE  
MARINETTE WI 54143  
800-328-1488  
INFO@MACTECHONSITE.COM

**MACTECH INTERNATIONAL**  
CONTACT US FROM ANYWHERE  
AROUND THE WORLD  
337-839-2793  
INFO@MACTECHOFFSHORE.COM

WORK HARD

WORK SAFE

WE BEFORE ME

WELCOME CHALLENGES

WOW THEM